

CM-312AE

HYPERCARDIOID HEADWORN CONDENSER MICROPHONE



The Crown® CM-312AE is a rugged, lightweight headworn microphone designed for aerobics, live entertainment, and sports broadcasting. It is intended for wireless-mic applications that require a light, inconspicuous mic.

The CM-312AE has no connector; you solder on a connector that mates with a wireless transmitter of your choice. Technical Bulletin #3 (included) shows the correct wiring for various transmitters.

Because the microphone is to the side of the mouth, breath pops are eliminated. The sound of the CM-312AE can be tailored to taste by moving the microphone closer or farther from the corner of the mouth.

The CM-312AE sounds like the best handheld microphones. Its hypercardioid pickup pattern reduces feedback and aids isolation. In difficult situations, the Crown CM-311AE headworn mic is recommended because it picks up even less feedback and leakage than the CM-312AE.

Designed for comfort, the headband fits behind the head and disappears in use. Both the headband and boom adjust to fit any head. Because of the boom's unique behind-the-ear design, it does not cover up the user's face.

How to adjust for best fit

For best results, the CM-312AE MUST be custom fitted to one wearer's head. This simple procedure takes only a few minutes. Please refer to Fig. 3 and locate the parts described.

1. If the microphone is for yourself, we suggest that you use a mirror to double check the fit as you make adjustments.
2. Loosen (just a little) the thumbscrew located on the outside of the foam block, part way back on the boom. This allows the boom to slide in and out, and to rotate left and right.
3. Now adjust the headband to fit your head. Put the foam block wire behind your ear.

Start bending the headband wire from the boom side, moving around to the other ear. The back of the headband should fit firmly against the back of the neck. If you can slide a finger between the headband and the back of your neck, then the headband is not fitted correctly. For users with smaller or petite heads, you may have to re-bend the earpiece around the ear, and cut off extra headband material.

4. Next, adjust the foam pad snug against your head or neck. To do this, bend the wire that goes into the foam block. CAUTION! Do not bend the boom itself – just the foam-block wire. A snug fit of the foam pad prevents boom bounce when you move around.

Specifications

Transducer type: Electret condenser.

Frequency response (typical): 50 Hz to 17,000 Hz (see Fig. 1).

Polar pattern: Hypercardioid (see Fig. 2).

Impedance: 6 kilohms unbalanced.

Recommended load impedance: 10 kilohms.

Open-circuit sensitivity, typical, close-talking: 2.9 mV/Pa* (-51 dB re 1V/Pa*).

Power sensitivity, typical, close-talking: -65 dB re 1 mW/Pa*.

Equivalent noise level (self noise): 31 dB SPL typical (0 dB = 0.0002 dyne/cm²), A-weighted.

S/N ratio: 63 dB at 94 dB SPL.

Maximum SPL: 148 dB SPL produces 3% THD.

Operating voltage: 3–9V DC from the transmitter's battery.

Polarity: Positive pressure on diaphragm produces positive voltage on white lead with respect to shield.

Current drain: 0.27 mA nominal.

Battery life: Approximately equal to transmitter battery life.

Operating temperature range: -18° to +57° C, or 0° to +135° F.

Off-attenuation: 70 dB @ 1kHz.

Output connectors: Supply your own to match your transmitter.

Cable: 45-inches long (1.14-m), 2-conductor shielded unbalanced cable, unterminated. In-line with this cable is a small circuit module that equalizes the microphone signal. White lead is audio, red lead is DC bias, and shield is ground.

Materials: High-impact plastic and PVC mic housing, brass boom, steel wire headband.

Finish: Satin black.

Net weight: 1.5 oz (43 g).

Dimensions: Headband 5.5 in. (13.97 cm) diameter, adjustable. Boom approximately 5.75 in. (14.61 cm). See Fig. 6.

Included accessories: Microphone carrying case, WS-7 foam pop filter and clothing clip for aerobics.

*1 pascal = 10 dynes/cm² = 10 microbars = 94 dB SPL.

Fig. 1

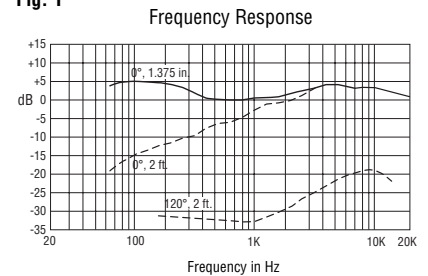

Fig. 2

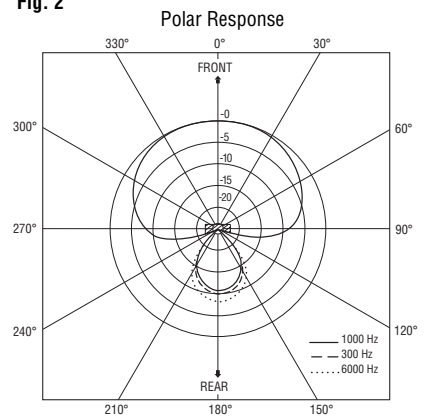
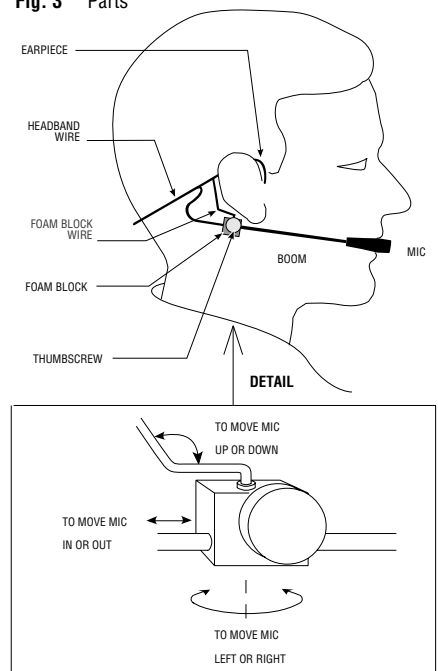

Fig. 3





PORTABLE PA



TOURING



RECORDING BROADCAST

CM-312AE

The closer the mic is to your mouth, the bassier is the tone. Adjust the position for the sound you prefer. If you hear breath pops, move the mic farther to the side of your mouth (Fig. 4). Tighten the thumbscrew.

Fig. 4

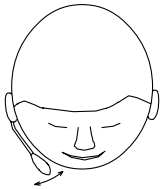

Adjust mic position to prevent breath pops.

Once you've adjusted the headset, it should remain in that position – no further adjustments are needed.

When using the mic for aerobics, you'll need to keep the cable in place. To do this, attach the cable to the clothes clip (included), and clip it to the back of your shirt. As shown in Fig. 5, be sure that the cable droops BELOW the clip. That way, sweat drips off the cable instead of into your transmitter.

Additional clothing clips can be ordered from Crown's Parts Department.



Fig. 5 Let the cable droop below the clip to shed moisture.

How to connect the CM-312AE to a wireless transmitter

1. Solder on a connector that mates with your transmitter. Technical Bulletin #3 (included) shows the correct wiring for various transmitters.
2. Plug in the cable. Adjust the trim pot on the transmitter input to prevent distortion.

Architects' and Engineers' Specifications

The microphone shall be the Crown Model CM-312AE or equivalent. The microphone shall be a headworn hypercardioid type of electret-condenser design. The microphone shall exhibit excellent off-axis response and gain-before-feedback. The microphone shall have an adjustable headband, adjustable boom with locking thumbscrew, and foam pop filter.

The microphone shall have a 45-inch (1.14-m), permanently attached, two-conductor shielded unterminated cable that can be connected to a transmitter. Powering shall be 3–9V from the transmitter.

Nominal open-circuit sensitivity shall be 2.9 mV/Pa. Maximum SPL shall be 148 dB SPL for 3% THD. Equivalent noise shall be 31 dBA nominal. Frequency response shall be 50 Hz to 17,000 Hz with a uniform off-axis response, over 20 dB down at the rear nulls. The Crown model CM-312AE is specified.

Fig. 6

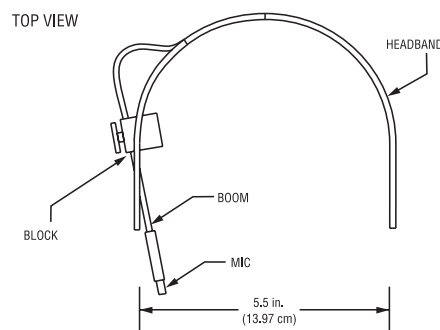

SIDE VIEW

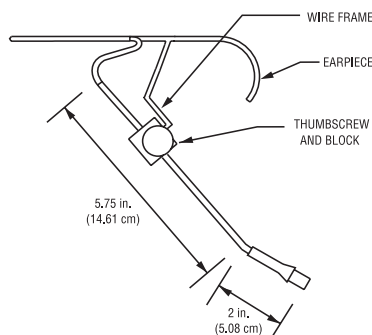

Warranty

Crown professional microphones are guaranteed against malfunction for a period of three years from date of original purchase. Please refer to the enclosed full warranty statement for more detail.

Service

If the microphone does not function properly, check that it is aimed correctly and is connected as described in this datasheet.

If you determine that the microphone product is defective, return the complete product in its original packaging to **Crown Factory Service, 1718 W. Mishawaka Road, Elkhart, IN 46517-9439. A Service Return Authorization (SRA) is required for product being returned for service. An SRA can be completed on line at:**

www.crownaudio.com/support/factserv.htm.

For further assistance or technical support call **800-342-6939**.



H A Harman International Company

Crown International, Inc.
1718 W. Mishawaka Rd.
Elkhart, IN 46517-9439
TEL: 574-294-8000
FAX: 574-294-8FAX
www.crownaudio.com

© 2008 Crown Audio®, Inc. Specifications subject to change without prior notice. Latest information available at www.crownaudio.com. Crown and Crown Audio are registered trademarks of Crown International.